

AQUA LUNG

Authorized Technician

TECHNICAL MAINTENANCE MANUAL



CONSHELF XIV

First and Second Stage

Contents

COPYRIGHT NOTICE	3
INTRODUCTION	3
WARNINGS, CAUTIONS, & NOTES	3
SCHEDULED SERVICE	3
GENERAL GUIDELINES	3
GENERAL CONVENTIONS	4
DISASSEMBLY PROCEDURES	4
FIRST-STAGE DISASSEMBLY	4
SECOND-STAGE DISASSEMBLY	5
AUTHORIZED REGULATOR REASSEMBLY	6
First Stage Resassembly	6
SECOND STAGE REASSEMBLY	8
AUTHORIZED REGULATOR ADJUSTMENT AND TESTING	9
ATTACHMENT OF FIRST-STAGE TO SECOND-STAGE REGULATORS	9
FIRST-STAGE ADJUSTMENT AND TESTING	10
SECOND-STAGE ADJUSTMENT AND TESTING	10
SECOND-STAGE AIR FLOW TEST	10
SECOND-STAGE OPENING EFFORT TEST	11
SECOND-STAGE PURGE FLOW TEST	11
OCTOPUS FLOW TEST	11
OCTOPUS OPENING EFFORT TEST	11
OCTOPUS PURGE FLOW TEST	11
LEAKAGE TEST	11
SUBJECTIVE BREATHING TESTING	11
AUTHORIZED REGULATOR ADJUSTING AND TESTING: NON-FLOW BENCH PROCEDURES	12
SECOND-STAGE ADJUSTMENT AND TESTING	12
SECOND-STAGE AIR FLOW	12
OPENING EFFORT CHECK	13
LEAKAGE TESTING	13
SUBJECTIVE BREATHING TESTING	13
TABLE 1 - FIRST-STAGE TROUBLESHOOTING GUIDE	14
TABLE 2 - SECOND-STAGE TROUBLESHOOTING GUIDE	15
TABLE 3 - RECOMMENDED TOOL LIST	16
TABLE 4 - RECOMMENDED LUBRICANTS AND CLEANERS	17
TABLE 5 - TORQUE SPECIFICATIONS	18
TABLE 6 - TEST BENCH SPECIFICATIONS	18
PROCEDURE A - CLEANING AND LUBRICATION	19
SECOND-STAGE EXPLODED PARTS DRAWING	20
FIRST-STAGE EXPLODED PARTS DRAWING	21

COPYRIGHT NOTICE

This manual is copyrighted, all rights reserved. It may not, in whole or in part, be copied, photocopied, reproduced, translated, or reduced to any electronic medium or machine readable form without prior consent in writing from Aqua Lung America. It may not be distributed through the internet or computer bulletin board systems without prior consent in writing from Aqua Lung America.

©2002 Aqua Lung America, Inc.
Conshelf XIV Service Manual

INTRODUCTION

This manual provides factory prescribed procedures for the correct service and repair of the Aqua Lung Conshelf XIV regulator. It is not intended to be used as an instructional manual for untrained personnel. The procedures outlined within this manual are to be performed only by personnel who have received factory authorized training through an Aqua Lung Service & Repair Seminar. If you do not completely understand all of the procedures outlined in this manual, contact Aqua Lung to speak directly with a Technical Advisor before proceeding any further.

WARNINGS, CAUTIONS, & NOTES

Pay special attention to information provided in warnings, cautions, and notes that are accompanied by one of these symbols:



WARNINGS indicate a procedure or situation that may result in serious injury or death if instructions are not followed correctly.



CAUTIONS indicate any situation or technique that will result in potential damage to the product, or render the product unsafe if instructions are not followed correctly.



NOTES are used to emphasize important points, tips, and reminders.

SCHEDULED SERVICE

If the regulator is subjected to less than 50 dives per year, it is permissible to overhaul it every other year with an inspection procedure being performed on the "off" years. For example:

Year #1: Inspection; Year #2: Overhaul; Year #3: Inspection
Year #4: Overhaul, and so on.

Both Inspections and Overhauls need to be documented in the *Annual Service & Inspection Record* in the back of the Owner's Manual to keep the *Limited Lifetime Warranty* in effect.

If a regulator is subjected to more than 50 dives per year, it should receive the complete overhaul.

An Official Inspection consists of:

1. A pressurized immersion test of the entire unit to check for air leakage.
2. Checking for stable intermediate pressure that is within the acceptable range.
3. Checking for opening effort that is within the acceptable range.
4. A visual inspection of the filter for debris or discoloration.
5. A visual inspection of the exhaust valve to see that it is in good shape and that it's resting against a clean surface.
6. A visual inspection of the mouthpiece looking for tears or holes.
7. Pulling back hose protectors and checking that the hoses are secure in the hose crimps.

If a regulator fails item #1,2,3 or 4 the entire regulator should be overhauled. If a regulator fails 4,5,6 or 7 it will be up to the technician's discretion whether or not a full overhaul is required.

GENERAL GUIDELINES

1. In order to correctly perform the procedures outlined in this manual, it is important to follow each step exactly in the order given. Read over the entire manual to become familiar with all procedures before attempting to disassemble the first-stage, and to learn which specialty tools and replacement parts will be required. Keep the manual open beside you for reference while performing each procedure. Do not rely on memory.
2. All service and repair should be carried out in a work area specifically set up and equipped for the task. Adequate lighting, cleanliness, and easy access to all required tools are essential for an efficient repair facility.
3. The regulator body will need to be secured in a vise when removing the spring retainer (28). NEVER SECURE THE REGULATOR BODY DIRECTLY IN A VISE. Instead, install a vise mounting tool (PN 100395) into the high pressure port, then secure the vise mounting tool in the vise. If you do not have a vise mounting tool, use an EXPIRED CO₂ cartridge attached to a high pressure adapter (3/8" female to 7/16" male). Never screw a CO₂ directly into a low pressure port in case the neck of the CO₂ cartridge breaks off, leaving the threads stuck in the regulator.
3. As the regulator is disassembled, reusable components should be segregated and not allowed to intermix with nonreusable parts or parts from other units. Delicate parts, including inlet fittings and crowns which contain critical sealing surfaces, must be protected and isolated from other parts to prevent damage during the cleaning procedure.
4. Use only genuine Aqua Lung parts provided in the overhaul parts kit. DO NOT attempt to substitute an Aqua Lung part with another manufacturer's, regardless of any similarity in shape or size.

- Do not attempt to reuse mandatory replacement parts under any circumstances, regardless of the amount of use the product has received since it was manufactured or last serviced.
- When reassembling, it is important to follow every torque specification prescribed in this manual, using a calibrated torque wrench. Most parts are made of either marine brass or plastic, and can be permanently damaged by undue stress.

GENERAL CONVENTIONS

Unless otherwise instructed, the following terminology and techniques are assumed:

- When instructed to *remove*, *unscrew*, or *loosen* a threaded part, turn the part counterclockwise.
- When instructed to *install*, *screw in*, or *tighten* a threaded part, turn the part clockwise.
- When instructed to remove an o-ring, use the pinch method (see figure) if possible, or use a brass or plastic o-ring removal tool. Avoid using hardened steel picks, as they may damage the o-ring sealing surface. All o-rings that are removed are discarded and replaced with brand new o-rings.

Pinch Method

Press upwards on sides of o-ring to create protrusion. Grab o-ring or insert o-ring tool at protrusion to remove.

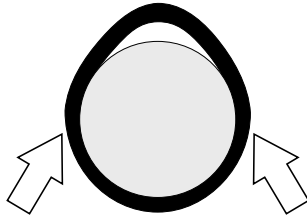

- The following acronyms are used throughout the manual: MP is Medium Pressure; HP is High Pressure; IP is Intermediate Pressure.
- Numbers in parentheses reference the key numbers on the exploded parts schematics. For example, in the statement, "...remove the o-ring (8) from the...", the number 8 is the key number to the crown o-ring.

DISASSEMBLY PROCEDURES

Note: Before performing any disassembly, refer to the exploded parts drawing, which references all mandatory replacement parts. These parts should be replaced with new, and must not be reused under any circumstances - regardless of the age of the regulator or how much use it has received since it was last serviced.

CAUTION: Use only a plastic or brass o-ring removal tool (PN 944022) when removing o-rings to prevent damage to the sealing surface. Even a small scratch across an o-ring sealing surface could result in leakage. Once an o-ring sealing surface has been damaged, the part must be replaced with new. DO NOT use a dental pick, or any other steel instrument.

FIRST-STAGE DISASSEMBLY

- Using a $\frac{9}{16}$ -inch open-end wrench, turn the wrench counterclockwise and remove the intermediate-pressure hose (26) from the first-stage body (Item 16). Also remove the high-pressure gauge hose with a $\frac{5}{8}$ -inch open-end wrench and, if present, the low-pressure inflator hose with a $\frac{1}{2}$ -inch open-end wrench.
- While holding the inlet fitting (Item 11) with a $\frac{3}{4}$ -inch open-end wrench, use an $\frac{11}{16}$ -inch open-end wrench to unscrew counterclockwise and remove the swivel end of the intermediate-pressure hose.
- Remove and discard the O-rings (Items 25 and 27) from the intermediate-pressure hose.
- If the high-pressure hose of the pressure gauge, requires the use of the special H.P. adapter (Item 22), remove the adapter by turning it counterclockwise, using an $\frac{11}{16}$ -inch wrench. Remove and discard the adapter O-ring.
- Remove and discard all O-rings of the low-pressure inflator and/or the high-pressure hose of the pressure gauge.

CAUTION: NEVER attempt to secure the first-stage body by direct clamping in a vise. This will result in damage to the regulator body requiring replacement of this part.

CAUTION: Empty CO₂ cartridge used for vise mounting should not be an old rusty cartridge from a Buoyancy Control Device. A new cartridge should be placed in a CO₂ firing mechanism and discharged.

- Screw an empty CO₂ cartridge clockwise into one of the low-pressure ports on the first-stage body (Item 16). Mount the first-stage body in a bench vise, mainspring side facing upward, by means of the CO₂ cartridge. (See Figure 1).

Figure 1

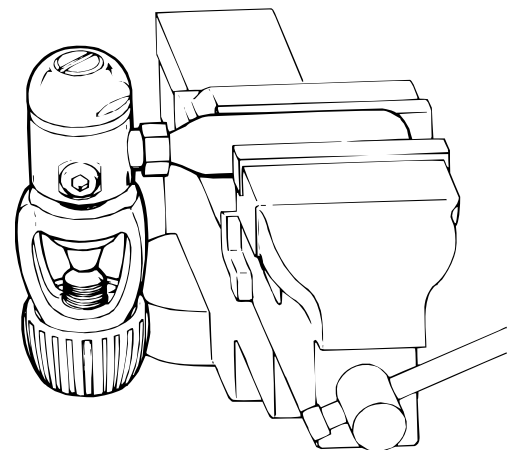

- Standard Conshelf (Non-Supreme Model): Using a large flat-bladed screwdriver, place the blade in the slot of the adjustment screw (Item 31). Turn the screwdriver counterclockwise and remove the adjustment screw. Lift out the washer (Item 30). Next remove the mainspring (Item 29).

- 7B. Conshelf Supreme: Using the slotted tool (PN 081247) place the tool in the two slots of the secondary diaphragm retaining ring (Item 34), turn the tool counterclockwise and remove the retainer. Next, using your fingertips, lift upward on the secondary diaphragm (Item 33) and remove it. Remove the first-stage from the bench vise and pour out and discard the silicone fluid. Finally, remount the first-stage in the vise in its former orientation to complete the disassembly of the low-pressure side. Using a large flat-bladed screwdriver, place the blade in the slot on the adjustment screw (Item 31). Turn the screwdriver counterclockwise and remove the adjustment screw. Lift out the mainspring (Item 29).
8. With a 1 $\frac{3}{4}$ -inch “crow’s foot” and breaker bar, turn the wrench counterclockwise and remove the spring retainer (Item 28). Lift out the spring pad (Item 27) and the thrust washer (Item 26).

CAUTION: DO NOT attempt to “pry” the diaphragm out of the first-stage, as the diaphragm seating shoulders in the first-stage will be scratched, requiring replacement of the body (Item 16).

9. Secure the dust cap (Item 3) in place by means of the yoke screw (Item 2). Using the low-pressure filtered air directed down through a low-pressure port on the first-stage body (Item 16), blow out the primary diaphragm (Item 25). (See Figure 2). Discard the used diaphragm.

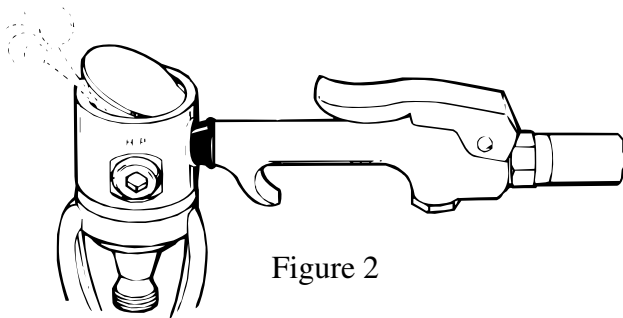

Figure 2

NOTE: Depending on how firmly the diaphragm is retained on its supporting “seat”, the low-pressure port plugs (Item 20) may have to be in place when using low-pressure filtered air to blow out the primary diaphragm.

10. Remove the first-stage from the bench vise. Lift out the pin pad (Item 18) and pin (Item 17).
11. Mount the first-stage with the yoke screw facing up in the bench vise by means of the CO₂ cartridge.
12. Unscrew the yoke screw (Item 2) counterclockwise and remove it from the yoke (Item 6).
13. Disengage and remove the dust cap (Item 3). Remove and discard the O-ring (Item 4).
14. Using external retaining-ring pliers, remove the yoke retaining ring (Item 5) from the groove on high-pressure inlet boss of the first-stage body. Then, turning the yoke counterclockwise, unscrew and remove it from the first stage.

CAUTION: The retaining ring (Item 7) must be removed carefully as the components beneath it are under spring tension. Failure to place your finger over the sintered filter (Item 9) while removing the retaining ring will cause loss or damage of these parts.

15. With internal retaining-ring pliers, remove the retaining ring and washer (Items 7 and 8) from the high-pressure inlet boss. Discard the used retaining ring and washer.
16. The sintered filter (Item 9) will pop out with the retaining ring and washer. Remove and discard the sintered filter.
17. Lift out the spring (Item 10), spring block (Item 11), high-pressure seat spring (Item 14), and the high-pressure seat (Item 15). Discard the used seat.

CAUTION: Use EXTREME care when removing O-rings from grooves. Even a small scratch across an O-ring sealing surface will result in leakage. Once an O-ring sealing surface has been damaged, the part must be replaced.

18. Located inside the spring block (Item 11) is an O-ring and backup ring (Items 13 and 12). Remove and discard both the O-ring and backup ring.
19. Remove the first-stage body from the vise. Remove the CO₂ cartridge from the body by turning the cartridge counterclockwise.
20. Using a 1/2-inch wrench unscrew any remaining low-pressure port plugs (Item 20). Remove and discard the port-plug O-rings (Item 19).

This concludes the disassembly of the Conshelf First-Stage Regulator.

SECOND-STAGE DISASSEMBLY

21. Using a #2 Phillips screwdriver, unscrew the clamping screw (Item 6) counterclockwise and remove it. Carefully remove the clamp ring (Item 5).
22. Lift off the box top (Item 4) and remove the second-stage diaphragm (Item 8).
23. Using external snap ring pliers, remove the retaining ring (Item 7); then the purge button (Item 2) and its spring (Item 3) from the box top (Item 4). Separate the spring from the purge button.

CAUTION: During removal of the inlet fitting (Item 11) depress the lever (Item 20). Failure to keep the lever depressed could cause damage to the sealing surface of the inlet fitting (Item 11).

24. With the lever depressed, use a 3/4-inch wrench to unscrew counterclockwise and remove the inlet-fitting (Item 11). Remove and discard the inlet-fitting external O-ring (Item 12).

CAUTION: The disc and retainer assembly (Item 13 and 14) is under spring tension. Care should be taken when removing these parts. This will help prevent damage or loss of parts.

25. **Conshelf 14 with port plug only:** If the second stage has a port plug (item 18), remove the port plug by turning it counterclockwise with a 4mm hex wrench. Remove and discard the O-ring (item 17).
26. Fit the disc and retainer wrench (U.S.D. P/N 110005) over the disc end of the retainer (Item 14). Hold the locknut (Item 22) with a ¼-inch box end wrench (older version) or with a ¼" nutdriver inserted through the open port (newer version). Turn the disc and retainer wrench counterclockwise and remove the locknut (Item 22). Discard the used locknut.
27. Remove the spacer (Item 21), lever (Item 20) and washer (Item 19) from inside the box bottom.
28. Next, remove the retainer (Item 14) and the spring (Item 15) from the inlet boss of the box bottom. Discard the used disc (Item 13) that is located in the larger end of the retainer.
29. Snip the plastic mouthpiece clamp (Item 23) with pliers or, with care, use wire cutters and remove it. Next, pull off the mouthpiece (Item 24).
30. To remove the exhaust tube (Item 9) from the box bottom (Item 16), place the second-stage in hot water at 200°F until the exhaust tube softens sufficiently to pull off.

CAUTION: Do not “twist” the exhaust tube (Item 42) during its removal, as the locating lug inside will be damaged.

31. Grasp the exhalation valve (Item 10) and remove it from the box bottom. Discard the used valve.

This concludes the disassembly of the Conshelf Second-Stage Regulator.

Before starting reassembly, perform parts cleaning and lubrication according to the procedures outlined in Procedure A, titled Cleaning & Lubrication, on page 19.

AUTHORIZED REGULATOR REASSEMBLY

This subsection presents a detailed, step-by-step reassembly procedure for the Conshelf 14 and Supreme Regulator Series. Unless noted otherwise, this procedure applies to both the Conshelf 14 and Supreme models. Specific references for the Conshelf 14 and Supreme are indicated when necessary. It is important that the sequence be followed exactly in the order given.

First Stage Resassembly

1. Screw an empty CO₂ cartridge into a low-pressure port on the first-stage body (Item 16). Mount the first-stage body in a bench vise, mainspring side facing upward, by means of the CO₂ cartridge. (See Figure 3)

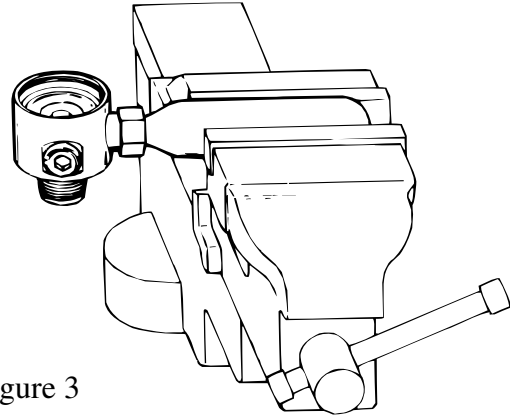

Figure 3

2. Lightly lubricate the port plug O-rings (Item 19 & 21) and place them on the corresponding first-stage port plugs (Item 20 & 23).
3. Install one in the low-pressure port plug (item 20) and high-pressure port plug (item 23). Using a ½-inch cross-foot attached to a torque wrench, tighten the port plugs to 15 inch-pounds.

NOTE: Do not install remaining port plug (Item 20). Set it aside for later installation. Leave the other two low-pressure ports open for connection to a test bench or intermediate-pressure test gauge (P/N 111610), and a second-stage hose during subsequent regulator adjustment and testing.

4. Insert the pin support (Item 18) into the center hole of the first-stage body.
5. Install a new primary diaphragm (Item 25) into the first-stage body over the pin support by pushing its edges down into the supporting “seat” of the body. This procedure can be completed by hand, or, if necessary, with the aid of a non-metallic flat-ended tool. The edges of the diaphragm should be evenly and firmly positioned in the support “seat”.

NOTE: If the primary diaphragm (Item 25) displays a rough and smooth side, place the smooth side down against the pin pad.

6. Place the gasket (Item 26) and, then, the spring pad (Item 27) on the diaphragm. Place the spring retainer (Item 28) over these two components and screw it clockwise completely onto the first-stage body to a torque of 20 ± 2 foot-pounds using a 1-3/4 inch torque wrench.

NOTE: There are two (2) different configurations of the low-pressure side of first-stage regulator. Read over Step 7 completely prior to reassembly of the regulator to become familiar with which procedure you should use.

7A. Standard Conshelf (Non-Supreme Model)

Insert the mainspring (Item 29) into the spring retainer, ensuring that the mainspring is centered over the spring pad, and then place the washer (Item 30) on top of the mainspring. Next, thread the adjustment screw (Item 31) clockwise over the mainspring and washer, then using a large flat-bladed screwdriver, continue to turn the adjustment screw clockwise until it is flush with the end of the spring retainer (see Figure 4).

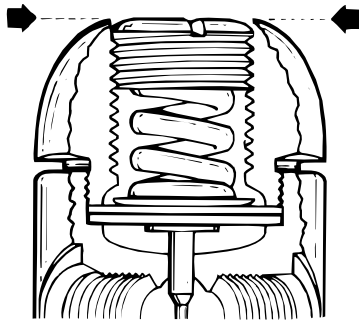

Figure 4

7B. Conshelf (Supreme)

Insert the mainspring (Item 29) into the spring retainer, ensuring that the mainspring is centered over the spring pad, and then place the adjustment screw (Item 31) over the protruding end of the mainspring. Next, using a large flat-bladed screwdriver, turn the adjustment screw clockwise until it is flush with the secondary diaphragm support shoulder of the spring retainer (see Figure 5). For the Conshelf Supreme, remember that a new supply of silicone fluid will be poured into the spring retainer (Item 32) after the intermediate-pressure adjustment is completed. After the procedure is finished, a new secondary diaphragm (Item 33) and secondary diaphragm retaining ring (Item 34) will be reinstalled. Refer to "[Authorized Regulator Adjustment and Testing](#)" on page 9.

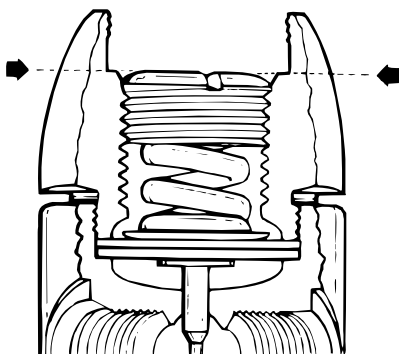

Figure 5

8. Now remove the first-stage body from the vise, then remove the empty CO₂ cartridge from the low-pressure port. Set the cartridge aside.
9. Install a new back-up ring (Item 12) and lightly lubricated O-ring (Item 13), in this order, into the open end of the spring block (Item 11). Set this assembly aside.

CAUTION: Use care when inserting the pin into the first-stage body; do not allow the pin to contact the machined seating orifice of the first-stage body.

10. While holding the small end of the new high-pressure seat (Item 15) in one hand, insert the end of the pin (Item 17) into the center of the seat. Then carefully insert the sub-assembly up into the center hole of the first-stage body. Gently "wiggle" this sub-assembly, if necessary, during this procedure to ensure that the end of the pin is completely seated in the pin support (Item 4).
11. While holding the high-pressure seat and pin assembly in place with one finger, turn the first-stage body over so that its threaded inlet boss is facing upward.
12. Insert the seat spring (Item 14), spring block assembly (Item 11) and spring (Item 10) into the inlet boss of the first-stage body.

13. Place the special high-pressure block guide (P/N 111000), recessed end downward, over the tip of the inlet boss of the first-stage body. Next, drop a new sintered filter (Item 9) with rough side facing upward into the spring block guide. Place a new washer (Item 8) over the filter. Next, place a new retaining ring (Item 7), flat side upward, on top of the washer and the sintered filter. (See Figure 6).

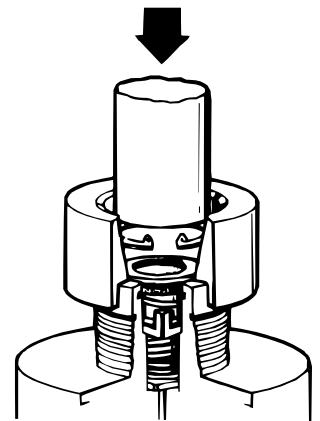

Figure 6

14. While holding the block guide, with the retaining ring centered over the hole and on top of the washer and filter, apply sufficient pressure downward against the retaining ring, using a 1/2-inch flat-end wood dowel (see Figure 7), to force the retaining ring through the guide until it fully "locks" in its own groove in the inlet boss. At this point, the seat spring, spring block, spring, and sintered filter should be correctly positioned and "locked" in the boss. Check this positioning carefully before proceeding.

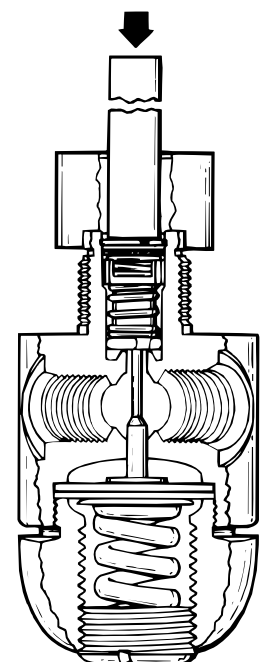

Figure 7

15. Next, completely thread the yoke (Item 6) clockwise onto the inlet boss of the first-stage body; then secure by installing the yoke retaining ring (Item 5) flat side facing upwards on the inlet boss using external snap-ring pliers.
16. Lightly lubricate the threads of the yoke screw (Item 2). Reinstall the yoke screw (Item 2) by turning it clockwise into the yoke (Item 6).
17. Install O-ring (Item 4), unlubricated, into the dust cap (Item 3) to complete the dust-cap assembly.
18. Wrap the nylon cord, tied to the dust cap, around one leg of the yoke and pass the cap through the loop formed, creating a "loose" knot.

This concludes the reassembly of the Conshelf First-Stage Regulator. Testing of the First-Stage Regulator will follow reassembly of the second-stage regulator.

SECOND STAGE REASSEMBLY

19. Insert the new disc (Item 13) into the bore provided for it on the retainer (Item 28).
20. Position the spring (15) over the stem of the retainer (Item 14).
21. Fit the disc and retainer with its spring onto the special disc and retainer wrench (P/N 110005), and carefully insert into the second-stage box bottom (Item 16).
22. Push inward on the wrench and hold momentarily so that the threaded stem of the retainer protrudes into the interior of the box bottom.
23. Immediately place the washer (Item 19), radiused end up, spacer (Item 21), and a new locknut (Item 22) onto the retainer. Turn the locknut clockwise until first threads are engaged.
24. Still pushing inward on the wrench, compressing the spring, insert the lever (Item 20) between the spacer and the washer (See Figure 8). Remove the disc and retainer wrench and assure that the lever is properly aligned in its groove on the box bottom.

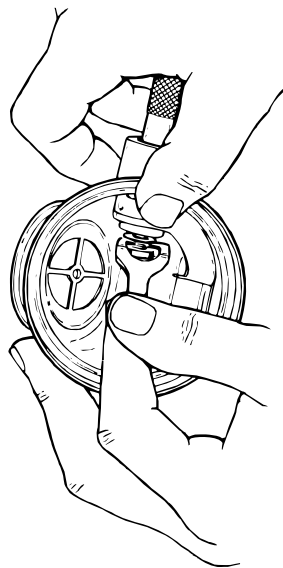

Figure 8

- 25a. **2nd stage without port plug:**
While holding the locknut with the ¼-inch box end wrench, reinsert the disc and retainer wrench over the end of the retainer (Item 28). Do not compress the spring. Turn the disc and retainer wrench clockwise until about three threads of the retainer are visible beyond the head of the locknut. Remove the disc and retainer wrench and ¼-inch wrench from the box bottom.
- 25b. **2nd stage with port plug:**
Insert a ¼" nutdriver through the open port and hold the locknut. Insert the disc and retainer wrench over the end of the retainer (Item 28). Do not compress the spring. While holding the retainer firmly, turn the ¼" nutdriver clockwise until about three threads of the retainer are visible beyond the head of the locknut. Remove the disc and retainer wrench and nutdriver from the box bottom.
26. Next, lightly lubricate the O-ring (Item 12) and place it on the inlet fitting (Item 11). To avoid marring the surface of the disc seat (Item 27), depress the lever and screw the inlet fitting (Item 11) clockwise into the inlet boss of the box bottom using a ¾-inch torque wrench, tighten the inlet fitting to a torque of 55 ± 5 inch-pounds.
27. At this point, the top of the lever (Item 20) should be approximately flush with the top surface of the box bottom (Item 16). Lay a straight edge or "sight" across the top surface of the box bottom to confirm correct lever height. If the tip of the lever is below the top surface of the box bottom, or if there is excessive "free play" or "flop" in the lever, use the following procedure:
 - a. **2nd stage without port plug:**
Hold the retainer (Item 14) stem with a small, bent-shank screwdriver and turn the locknut (Item 22) clockwise with a ¼-inch open-end wrench. Adjust only far enough to correct the lever height or eliminate excessive "free-play". (See Figure 9)

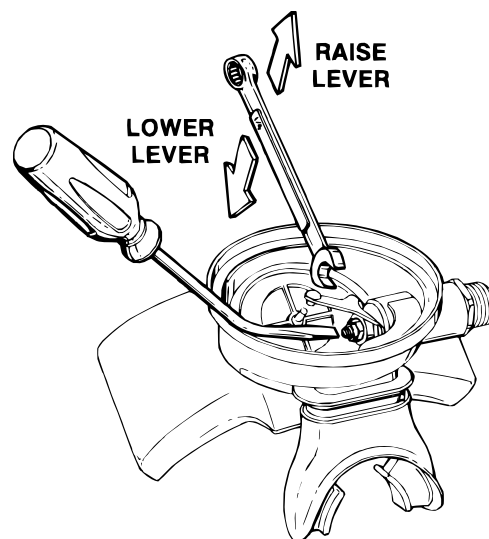

Figure 9

b. 2nd stage with port plug:

Insert the ¼" nut driver portion of the Lever Height Adjustment Tool (LHAT) through the open port and hold the locknut. Insert the screwdriver portion of the LHAT tool through the center of the nutdriver and insert it into the end of the disc retainer. While holding the disc retainer still with the screwdriver, turn the nutdriver clockwise to correct the lever height or eliminate excessive "free-play". (See Figure 10)

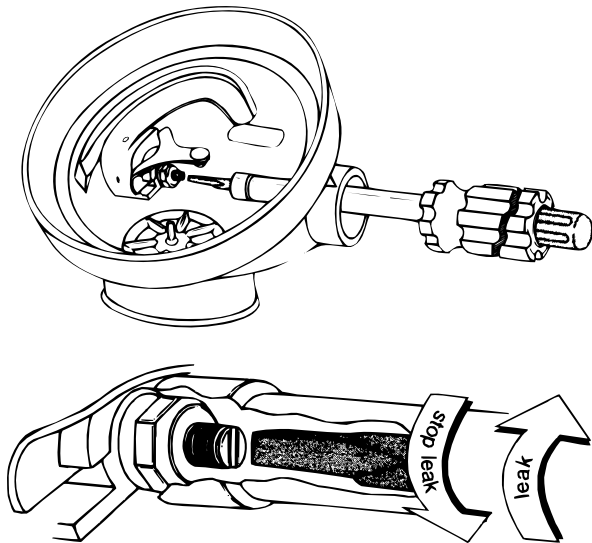



Figure 10

10. Insert the new exhalation valve (Item 10) into the box bottom (Item 16) and pull on the stem of the valve until its barb passes through the hole into the box bottom. Using the wire cutters, trim the stem end of the valve ⅛" to ¼" above the barb.
11. Rotate the spring (Item 3), small-end first, onto the purge button (Item 2).
12. Press the purge button (Item 2) sub-assembly through the box top (Item 4) and using external snap ring pliers, install a new retaining ring (Item 41) into its groove on the purge button inside the box top. Ensure that the radiused edge of the retaining ring faces toward the front of the box top.
13. Heat the exhaust tube (Item 9) in hot water at 200°F; then stretch it over the flange of the box bottom (Item 16). Ensure that the locating lug on the exhaust tube is aligned with its notch in the flange of the box bottom. Do not "twist" the exhaust tube over the flange or the locating lug will be damaged.
14. Fit the mouthpiece (Item 24) onto the box bottom, and fasten the mouthpiece in place with a new mouthpiece clamp (Item 23). The lock tab on the mouthpiece clamp should be aligned with the air inlet boss of the box bottom. Tighten with pliers and snip the extra length with wire cutters.

15. Second-stage with port plug only:

Install a new O-ring (item 17) onto the second-stage port plug (18). Thread the port plug into the second stage and tighten using a 4mm hex wrench.

 **NOTE:** Do not reinstall the diaphragm and box top assembly (Items 8 & 4) until final adjustment of second-stage assembly is completed.

AUTHORIZED REGULATOR ADJUSTMENT AND TESTING

 **NOTE:** Before placing the Conshelf Regulator back in service, the following sequence of adjustments is necessary. The use of a flow test bench is the preferred device to insure the quality of your adjustments. This will enable the service technician to check critical performance requirements of the Regulator series more precisely. If no test bench is available to the service technician, use of a SCUBA cylinder, the less preferred testing procedure will follow this section.

ATTACHMENT OF FIRST-STAGE TO SECOND-STAGE REGULATORS

1. Install the two lubricated O-rings (Items 25 and 27) on the intermediate-pressure hose (Item 26).
 2. Attach the hose (Item 26) to one of the low-pressure ports on the first-stage body (Item 16) using a ⅛-inch torque wrench. Tighten the hose clockwise to a torque of 40 inch-pounds.
-  **NOTE:** If the Octopus Regulator is to be used, attach the Octopus hose to the first-stage body as described in Steps 1 and 2. Connection of additional hoses, such as the pressure gauge or low-pressure inflator hose, should not be done until after complete testing of the first and second stage(s). This will simplify troubleshooting leakage problems, if they occur.
3. Connect the first-stage regulator to a source of low-pressure (500 psig) breathing air. While firmly holding the free end(s) of the second-stage hose(s), carefully open the air source control valve allowing a small quantity of air to flow through the open hose(s). This will flush any dust or debris from the interior of the hose(s).
 4. Close the air source control valve and attach the second-stage regulator(s) to the free end of the second-stage hose(s). While holding the inlet fitting (Item 11) with a ¾-inch wrench, use an 1⅛-inch torque wrench to tighten the swivel nut clockwise to a torque of 40 inch-pounds.

FIRST-STAGE ADJUSTMENT AND TESTING

 **NOTE:** In conjunction with this subsection, the technician should refer to Table 5 - Test Bench Specifications, on page 18. In addition, all tests described must first be done at low-pressure (500 psig) and then again at service pressure (3000 psig).

1. With the first stage regulator mounted on the test bench high-pressure valve block adapter, attach a spare intermediate-pressure hose to the open low-pressure port on the first-stage regulator. Attach the free end of this hose to the male fitting provided for it on the test bench. (If the Octopus regulator is attached to the first-stage regulator, removal of the port plug [Item 20] will be required).
2. While watching the intermediate-pressure gauge on the test bench, slowly pressurize the bench and regulator to 500 psig. The intermediate-pressure gauge should indicate a "lockup" pressure of 120 to 160 psig. If the gauge pressure increases beyond 160 psig, turn the air source off immediately. This indicates a failure of the first-stage regulator to achieve "lockup" pressure. Refer to the Troubleshooting Table 1 on page 14 for corrective guidelines and specific procedures. If the intermediate pressure is not greater than 160 psig but there is an audible leak or freeflow from the second-stage regulator(s), adjustment of the lever (Item 34) will be required before final adjustment of the first-stage intermediate pressure can be completed. To adjust the lever see "[Second-Stage Adjustment and Testing](#)", Step 2a or 2b, on this page

 **CAUTION:** While adjusting the intermediate pressure, be sure to "cycle" the regulator by pushing the purge button (Item 2) at least ten (10) times after turning the adjustment screw (Item 31). Failure to "cycle" the regulator can result in a false reading of the first-stage intermediate-pressure "lock-up".

3. The optimum lockup pressure is 140 ± 5 psig. To increase the intermediate pressure, turn the adjustment screw (Item 31) "in" or clockwise; to decrease the intermediate pressure, turn the adjustment screw "out" or counterclockwise. Turn the adjustment screw using a large flat-bladed screwdriver. Turn the screw no more than $\frac{1}{2}$ turn at a time, then purge the second stage several times and observe the adjustment's intermediate-pressure increase. Repeat this process until the intermediate pressure is 140 ± 5 psig.
4. If the acceptable range cannot be achieved by varying the adjusting screw (Item 11), refer to the Troubleshooting Table 1 on page 14 for corrective guidelines and specific procedures.
5. Assuming the correct intermediate-pressure has been achieved, depress the purge button (Item 2) several times, release and observe the test bench intermediate-pressure gauge 5 seconds to 15 seconds after purging. The intermediate-pressure indicated must not "creep" or slowly increase more than 5 psig within this time. If the intermediate-pressure will not stabilize at one pressure

setting, refer to the Troubleshooting Table 1 on page 14 for corrective guidelines and specific procedures.

6. After stabilizing the intermediate-pressure repeat Steps 2 through 5 at 3000 psig, service pressure.

For the Conshelf Supreme:

After completing the adjustment of the intermediate-pressure setting depressurize and remove the regulator from the test bench or cylinder valve. Then remount the first-stage body, using an empty CO₂ cartridge again, in the bench vise with the low-pressure side facing upward. The following procedure covers either the completion of the environmental conversion of a standard Conshelf 14 or reinstallation of environmental components on the Supreme Model.

- A. Pour silicone fluid into the spring retainer until the level reaches within $\frac{1}{8}$ -inch below the top of the retainer.
- B. Insert the secondary diaphragm (Item 33) into the spring retainer with the outer, raised lip pointing up. The diaphragm must be covered with silicone to function properly.
- C. Air bubbles underneath the secondary diaphragm must be removed by smoothing the diaphragm with the fingernail.
- D. Using the square, slotted tool provided with the conversion kit, screw the secondary-diaphragm retaining ring (Item 34) clockwise into the spring retainer. Hand-tighten firmly.
- E. Verify that the intermediate-pressure has not changed after the conversion or reinstallation procedure. Refer to the subsection on the first-stage adjustment as required.

SECOND-STAGE ADJUSTMENT AND TESTING

SECOND-STAGE AIR FLOW TEST

 **NOTE:** Prior to performing the second-stage adjustments and testing, installation of the diaphragm box top and ring clamp (Items 4 and 5) must be completed. To do this, proceed as follows.

1. Place the diaphragm, metal plate facing the lever (Item 8) onto the seating shoulder of the box bottom (Item 16).
2. Place the box top (Item 4) over the diaphragm. While holding the box top firmly in place, pressurize the regulator. There should be no audible leaks detected. While still holding the box top firmly in place, breathe from the mouthpiece several times and listen once again for any leaks. Next press the purge button several times, once again listen for any audible leaks. If leaks are detected, adjustment of the lever (Item 20) will be required. To adjust the lever, use the following method:

a. 2nd stage without port plug:

Hold the retainer (Item 14) stem with a small bent-shank screwdriver and turn the locknut (Item 22) counterclock-

wise with a ¼-inch open-end wrench. Adjust only far enough to correct the leakage problem. (See Figure 9).

b. 2nd stage with port plug:

Remove the port plug (item 18). Insert the ¼" nut driver portion of the Lever Height Adjustment Tool (LHAT) through the open port and hold the locknut. Insert the screwdriver portion of the LHAT tool through the center of the nutdriver and insert it into the end of the disc retainer. While holding the disc retainer still with the screwdriver, turn the nutdriver counterclockwise. (See Figure 10.) Adjust only far enough to correct the leakage problem. Reinstall the port plug (18)

3. Once you have eliminated the leak(s) refit the ring clamp (Item 49), such that the screw hole in the clamp, is lined up with the inlet fitting (Item 36) and the screw (Item 50) can be inserted into the clamp from the top of the box bottom (Item 30). Thread the screw, clockwise into the ring clamp (Item 49), first, by hand, then using a #2 Phillips screwdriver tighten the screw hand tight firmly.
4. With the regulator still attached to the flow test bench and pressurized to 3000 ± 100 psig, place the second-stage mouthpiece over the mouthpiece adapter. Slowly turn the flowmeter control knob until the flow reaches a minimum of 15 SCFM (425 litres per minute). The reading on the Magnehelic gauge (Inhalation/Exhalation Effort Gauge) should indicate no more than +0.6" of H₂O. If the reading is over +6.5" H₂O, refer to Troubleshooting Table 2 on pages 19 and 20 for corrective guidelines and specific procedures.

SECOND-STAGE OPENING EFFORT TEST

5. Next, shut off the flowmeter control knob. Slowly turn the flowmeter control knob back on while watching both the Magnehelic gauge and the intermediate pressure gauge. When the intermediate pressure gauge begins to drop below the intermediate pressure "lock up", the Magnehelic gauge should indicate an opening effort of +0.6" of H₂O to 1.5" of H₂O. If the opening effort is not within this range, refer to the Troubleshooting Table 2 on page 15 for corrective guidelines and specific procedures.

SECOND-STAGE PURGE FLOW TEST

6. Turn off flowmeter control knob. Next, while the second-stage regulator is still mounted on the mouthpiece adapter, watch the flowmeter gauge and fully depress the purge button. The flowmeter gauge must indicate a minimum of +5.0 SCFM (142 L.P.M.). If the purge flow is less than +5.0 SCFM, refer to the Troubleshooting Table 2 on page 15, for corrective guidelines and specific procedures. When purge flow is correct, remove the second-stage from the mouthpiece adapter on the flow test bench.

OCTOPUS FLOW TEST

 **NOTE:** If the Octopus regulator is attached to the first-stage regulator, the following are the test procedures for this regulator.

7. Mount the Octopus second-stage regulator on the mouthpiece adapter of the flow test bench. Slowly turn the flowmeter control knob until the flow reaches a minimum of 15 SCFM (425 L.P.M.). The reading on the Magnehelic gauge should indicate no more than +6.5" H₂O. If the reader is over +6.5" H₂O, refer to the Troubleshooting Table 2 on page 15, for corrective guidelines and specific procedures.

OCTOPUS OPENING EFFORT TEST

8. Shut off the flowmeter control knob. Slowly turn the flowmeter control knob back on while watching the Magnehelic gauge. The Magnehelic gauge should indicate an opening of +1.2" to +2.1" of H₂O. If the opening effort is not within its range, refer to the Troubleshooting Table 2 on page 15, for corrective guidelines and specific procedures.

OCTOPUS PURGE FLOW TEST

(See Step 6 above, same as second-stage purge flow test.)

LEAKAGE TEST

After final reassembly and adjustment of the Conshelf 14 Regulator, the following simple test for external leakage is recommended.

 **NOTE:** The mouthpiece of the regulator must point straight down or free-flow may result when submerged in water.

1. With the first and second-stages attached to a high-pressure air supply, submerge the entire system in a test tank of clean water.
2. Turn on the high-pressure air supply.
3. Observe any bubbles streaming from the submerged regulator over a one-minute period. This recommended time is necessary due to the lower bubble formation that occurs in cases of smaller leaks. Any bubbles noted indicate leakage with the need to disassemble and check all sealing areas, assembly sequence and component positioning in order to correct the problem(s).

NOTE: An alternative method for visually detecting regulator leakage is to apply soap solution to possible leakage areas using a small, clean brush. Bubble streams will pinpoint the source of leakage.

Before disassembling to correct any leakage problems, rinse the entire regulator thoroughly with fresh water and blow out all residual moisture with filtered, low-pressure (30 psig) air. Disassemble and remedy the problem, referring to the Troubleshooting Table as needed.

SUBJECTIVE BREATHING TESTING

1. In general, the properly overhauled and adjusted Conshelf 14 Regulator, upon breathing in and out of the mouthpiece slowly and deeply four or five times, should deliver air to the user without excessive inhalation effort,

freeflow, or “fluttering” of the second-stage diaphragm. In addition, when exhaling there should be no fluttering or sticking of the exhalation valve. If any of these problems occur, again refer to the Troubleshooting Table for corrective guidelines and specific procedures. Also, conduct a purge flow test; depress the purge button fully; an adequate volume of air should flow from the mouthpiece.

This concludes the adjustment and testing procedures for the Conshelf 14 Regulator Series.

AUTHORIZED REGULATOR ADJUSTING AND TESTING: NON-FLOW BENCH PROCEDURES

1. After attaching the first and second stages, (see *Attachment of First-stage to Second-stage Regulators*, steps 1 through 4, on page 9) use a spare intermediate-pressure hose (Item 48). Attach this hose to one of the open low-pressure ports on the first-stage body (Item 1). (If the Octopus regulator is attached to the first-stage regulator, removal of the port plug [Item 3] will be required.)

 **NOTE:** If no test bench is available for testing the Conshelf Regulator, the following adjustment and testing procedures should be followed.

2. Thread the intermediate test pressure gauge (P/N 111610) onto the free end of the intermediate-pressure hose. Make sure that the bleeder valve of the test pressure gauge is open prior to pressurizing the regulator.
3. Connect the first-stage regulator to a low-pressure air source (partially filled SCUBA cylinder - 500 psig). Slowly turn on the air source control knob and pressurize the regulator. Once the regulator is pressurized, slowly close the gauge bleeder valve while watching the test gauge. The gauge should indicate a “lockup” pressure of 120 to 160 psig. If the gauge pressure continues beyond 160 psig, immediately open the gauge bleeder valve and close the air-source control valve. Such a steadily increasing gauge pressure beyond 160 psig indicates failure of the first-stage regulator to achieve “lockup” pressure. Refer to the Troubleshooting Table 1, page 14, for corrective guidelines and specific procedures.
4. If the intermediate pressure is not greater than 160 psig but there is an audible leak or freeflow from the second-stage regulator(s), adjustment of the lever (Item 34) will be required before final adjustment of the first-stage intermediate pressure can be completed. To adjust the lever see page 12, “*Second-Stage Adjustment and Testing*”, Step 2a or 2b.



CAUTION: If an adjustment of intermediate-pressure is required, be sure to “cycle” (10 times) the regulator by pushing the purge button (Item 39) after turning the adjustment screw (Item 11). Failure to “cycle” the regulator can result in a false reading of the first-stage intermediate-pressure “lock-up”.

5. The optimum lockup pressure is 140±5 psig. To increase the intermediate pressure, turn the adjustment screw (Item 11) “in” or clockwise; to decrease the intermediate pressure, turn the adjustment screw “out” or counterclockwise. Turn the adjustment screw using a large flat-bladed screwdriver. Turn the screw no more than 1/8 turn at a time, then purge the second stage several times and observe the adjustment’s intermediate-pressure increase. Repeat this process until the intermediate pressure is 140±5 psig.
6. Assuming the correct intermediate-pressure has been achieved, depress the purge button (Item 39) several times, release and observe the intermediate-pressure gauge 5 seconds to 15 seconds after purging. The intermediate-pressure indicated must not “creep” or slowly increase more the 5 psig within this time. If the intermediate-pressure will not stabilize at one pressure setting, refer to the Troubleshooting Table 2, page 19, for corrective guidelines and specific procedures.
7. After stabilizing the intermediate-pressure repeat Steps 3 through 7 at 3000 psig, service pressure.

 **NOTE:** For the Conshelf Supreme: See page 7, Step 7b for environmental conversion or reinstallation or environmental components on the Supreme Model.

SECOND-STAGE ADJUSTMENT AND TESTING

Before final reassembly of the second-stage regulator and after preliminary adjustment of the lever, the following procedures are recommended. The first is a general purge flow test; the second provides an approximate performance evaluation of opening effort.

SECOND-STAGE AIR FLOW

1. With the Conshelf Regulator connected to a high-pressure air supply of 3,000 psig, turn on the air supply. If the sudden leakage or free flow into the second stage occurs, turn off the air supply immediately, and adjust the locknut outward (counterclockwise), lowering the lever height, until the leakage stops.
2. Assuming there is no leakage, fully depress the purge button. This should result in a moderate flowrate of air exiting from the mouthpiece.
3. Repeat this procedure several times. Refer to the Troubleshooting Tables, pages 14 and 15 to correct any air flow problems.

OPENING EFFORT CHECK

4. Assuming there are no airflow problems, next check the opening effort.



CAUTION: Do not allow water to enter the mouthpiece (Item 43), as the water will spray over the test area.

5. While holding the mouthpiece or exhaust tube (Items 24 or 9), slowly submerge the second-stage regulator, box top facing downward and level, into a pan of clean water to a depth of about one inch above the diaphragm.
6. This submersion should cause the second-stage to free flow, indicating an acceptable, but approximate, opening effort of one inch of water column.

LEAKAGE TESTING

(See Page 9 for this procedure.)

SUBJECTIVE BREATHING TESTING

(See Page 9 for this procedure.)

This concludes the adjustment and testing procedures for the Conshelf Regulator Series.

Table 1 - First-Stage Troubleshooting Guide

	SYMPTOM	POSSIBLE CAUSE	TREATMENT
FIRST STAGE	High pressure creep (also causes second-stage leaks)	1. HP Seat (5) is worn or damaged	1. Replace HP seat
		2. Machine seat orifice damaged.	2. Replace body (16)
		3. O-ring (4) damaged or worn.	3. Replace O-ring
		4. O-ring (13) damaged or worn	4. Replace O-ring
		5. Internal wall of spring block (11) scratched	5. Replace spring block
	External air leakage -Or- Secondary diaphragm distended or burst	1. Port plug o-rings (19 & 21) worn or damaged	1. Replace o-rings
		2. Diaphragm (25) worn or damaged	2. Replace diaphragm
		3. Diaphragm seating surface damaged	4. Replace body
		5. Spring retainer (28) loose	5. Tighten spring retainer
	Restricted air flow or high inhalation resistance through entire system	1. Cylinder valve not completely open	1. Open valve; check fill pressure
		2. Cylinder valve needs service	2. Switch to different cylinder
		3. Filter (9) is clogged	3. Replace filter

Table 2 - Second-Stage Troubleshooting Guide

	SYMPTOM	POSSIBLE CAUSE	TREATMENT
SECOND STAGE	Free Flow	1. Purge button (2) jammed open	1. Remove purge button
		2. Lever (20) set to high	2. Turn locknut counterclockwise to adjust lever downward
		3. Lever (20) bent	3. Replace lever
		4. Ice deposits on demand valve	4. Allow water to flow in to melt ice
		5. First-stage intermediate pressure set too high	5. Readjust IP to 140±5 psig
	Hard to breathe	1. Lever (20) bent	1. Replace lever
		2. Lever set too low	2. Turn locknut clockwise to adjust lever upward
		3. First-stage intermediate pressure set too low	4. Readjust IP to 140±5 psig
		5. First-stage filter (9) clogged	5. Replace filter
	Restricted air flow or high inhalation resistance through entire system	1. Cylinder valve not completely open	1. Open valve; check fill pressure
		2. Cylinder valve needs service	2. Switch to different cylinder
		3. Filter (9) is clogged	3. Replace filter
	Hissing sound from second-stage	1. Lever (20) set too high	1. Turn locknut counterclockwise to adjust lever downward
		2. First-stage intermediate pressure set too high	2. Readjust IP to 140±5 psig
		3. Low pressure seat (13) damaged or worn	3. Replace low pressure seat
		4. HP leak	4. Overhaul first-stage
		5. Inlet fitting (11) damaged	5. Replace inlet fitting
		6. Purge flow adjustment screw (2) out too far	6. Turn screw clockwise ½ turn at a time and retest
	Water entering second-stage	1. Hole in mouthpiece (24)	1. Replace mouthpiece
		2. Pinhole in diaphragm (8)	2. Replace diaphragm
3. Damaged exhaust valve (10)		3. Replace exhaust valve	
4. Second-stage diaphragm (8) improperly clamped between box top (4) and box bottom (16)		4. Disassemble and reassemble correctly	
5. Exhaust valve seating area damaged		5. Replace box bottom (16)	

Table 3 - Recommended Tool List

PART NO.	DESCRIPTION	APPLICATION
111610	I.P. test gauge	Intermediate pressure testing
944022	O-ring tool, set	O-ring removal and installation
111100	Reversible snap ring pliers	Circlip removal
101684	Lever Height Adjustment Tool (LHAT)	Second-stage adjustment (newer style second-stage)
100395	Vise mounting tool	Mounting first-stage into vise
110005	Disc Retainer Wrench	Second-stage disassembly/reassembly
111000	HP Spring Block Assembly Guide	First-stage reassembly
081247	Supreme Retainer Wrench	Secondary diaphragm retainer
n/a	Torque wrench, inch-pound	Second-stage Inlet fitting, hoses
n/a	Torque wrench, foot-pound	First-stage Inlet fitting, spring retainer, HP Plug
n/a	Breaker bar	Spring retainer removal (used with 1 3/4" crows-foot)
n/a	5/16" crows-foot	LP hose installation (used with torque wrench)
n/a	5/8" crows-foot	HP hose installation (used with torque wrench)
n/a	3/4" crows foot	Inlet fitting installation (used with torque wrench)
n/a	1 3/4" crows-foot	Spring retainer removal (used with breaker bar)
n/a	#2 Phillips screwdriver	Box top retaining ring
n/a	Bent shaft, small blade screwdriver	Lever height adjustment (older style second stage)
n/a	1/4" wrench	Locknut (older style second stage)
n/a	1/2" wrench	Port plugs
n/a	5/16" wrench	LP hose removal
n/a	5/8" wrench	HP hose removal
n/a	3/4" wrench	Inlet fitting removal
n/a	Large, flat blade screwdriver	Adjustment screw

Table 4 - Recommended Lubricants & Cleaners

LUBRICANT / CLEANER	APPLICATION	SOURCE
Christo-Lube® MCG-111	All O-rings seals	Aqua Lung, PN 820466, or Lubrication Technologies 310 Morton Street Jackson, OH 45640 (800) 477-8704
<div style="border: 1px solid black; padding: 5px; margin: 10px auto; width: 80%;"> <p>CAUTION: Silicone rubber requires no lubrication or preservative treatment. DO NOT apply grease or spray to silicone rubber parts. Doing so may cause a chemical breakdown and premature deterioration of the material.</p> </div>		
Oakite #31	Acid bath for reusable stainless steel and brass parts.	Oakite Products, Inc. 50 Valley Road Berkeley Heights, NJ 07922
White distilled vinegar (100 gr.)	Acid bath for reusable stainless steel and brass parts.	"Household" grade
<div style="border: 1px solid black; padding: 5px; margin: 10px auto; width: 80%;"> <p>CAUTION: DO NOT use muriatic acid for the cleaning of any parts. Muriatic acid, even when strongly diluted, can harm chrome plating, and may leave a residue that is harmful to O-ring seals and other parts.</p> </div>		
Liquid dishwashing detergent (diluted with warm water)	Degreaser for brass and stainless steel parts; general cleaning solution for plastic and rubber	"Household" grade

Table 4 - Torque Specifications

DESCRIPTION (KEY NUMBER)	TORQUE
Spring retainer (28)	25±2 foot-lbs
Second-stage Inlet Fitting (11)	55±5 inch-pounds
Hose fittings (26)	40 inch-pounds
Port plugs (19, 23, 24, 22)	15 inch-pounds

Table 5 - Test Bench Specifications

TEST	CONDITION	ACCEPTABLE RANGE
Leak Test	Inlet 2,500-3,000 (±100) psig	No leaks allowed
Intermediate Pressure	Inlet 2,500-3,000 (±100) psig	135±5 psi
Intermediate Pressure Creep	Inlet 2,500-3,000 (±100) psig	5 psi max between 5 to 15 seconds after cycling (purging) regulator
Opening effort	Inlet 2,500-3,000 (±100) psig	0.6 to 1.5" of water (Standard) 1.2 to 2.1" of water (Octopus)
Purge flow	Inlet 2,500-3,000 (±100) psig	+5.0 SCFM (142 L.P.M.) Minimum

Procedure A

Cleaning & Lubrication

(All Aqua Lung Regulators)

Brass and Stainless Steel Parts

1. Preclean in warm, soapy water* using a nylon bristle tooth brush.
2. Thoroughly clean parts in an ultrasonic cleaner filled with soapy water. If there are stubborn deposits, household white distilled vinegar (acetic acid) in an ultrasonic cleaner will work well. DO NOT place plastic, rubber, silicone or anodized aluminum parts in vinegar.
3. Remove parts from the ultrasonic cleaner and rinse with fresh water. If tap water is extremely "hard," place the parts in a bath of distilled water to prevent any mineral residue. Agitate lightly, and allow to soak for 5-10 minutes. Remove and blow dry with low pressure (25 psi) filtered air, and inspect closely to ensure proper cleaning and like-new condition.

Anodized Aluminum, Plastic & Rubber Parts

Anodized aluminum parts and parts made of plastic or rubber, such as box bottoms, box tops, dust caps, etc., may be soaked and cleaned in a solution of warm water mixed with mild dish soap. Use only a soft nylon toothbrush to scrub away any deposits. Rinse in fresh water and thoroughly blow dry, using low pressure filtered air.

 **CAUTION:** Do not place plastic and rubber parts in acid solutions. Doing so may alter the physical properties of the component, causing it to prematurely degrade and/or break.

Hoses

If buildup of corrosion is severe, it is permissible to soak only the hose fittings in the ultrasonic cleaner as needed, and not allow any solution to enter the hose. Rinse in fresh water and allow to dry with the cleaned ends hanging down. Blow filtered air through them prior to installing onto the regulator.

Lubrication and Dressing

All o-rings should be lubricated with Christo-Lube® MCG-111. Dress the o-rings with a very light film of grease, and remove any visible excess by running the o-ring between thumb and forefinger. Avoid applying excessive amounts of Christo-Lube grease, as this will attract particulate matter that may cause damage to the o-ring.

*Soapy water is defined as "household" grade liquid dishwashing detergent diluted in warm water.

Second-Stage Exploded Parts Drawing

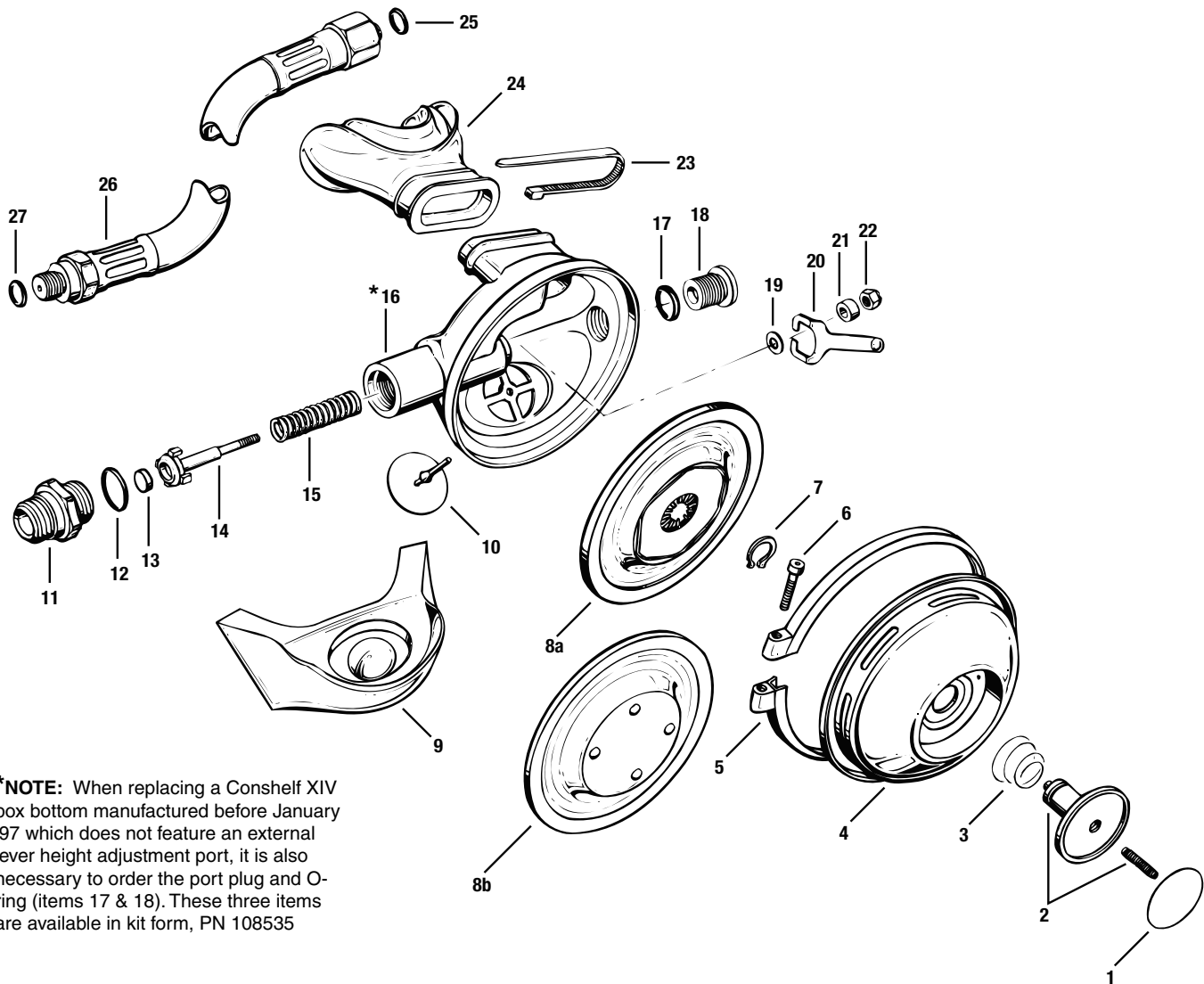

***NOTE:** When replacing a Conshelf XIV box bottom manufactured before January '97 which does not feature an external lever height adjustment port, it is also necessary to order the port plug and O-ring (items 17 & 18). These three items are available in kit form, PN 108535

Key #	Part #	Description	Key #	Part #	Description
-----	108530	Conshelf XIV 2nd Stage w/o hose	18----	102004	Plug
-----	108538	Conshelf XIV Supreme 2nd Stage w/o hose	19----	845022	Washer
-----	900007	Overhaul Parts Kit	-----	107607	Washer (Cold Water)
1----	108185	Decal, Conshelf XIV	20----	108513	Lever
2----	103706	Purge Button w/ Adjustment Screw	-----	107605	Lever (Cold Water)
3----	102708	Purge Spring	21----	102517	Spacer
4----	107001	Box Top	-----	107606	Spacer (Cold Water)
5----	390147	Box Top Clamp	22----	102510	Locknut
6----	834023	Clamp Screw	23----	104940	Clamp, Clear
7----	860037	Retaining Ring	-----	104913	Clamp, Black
8a----	100571	Demand Diaphragm, Liquid Injection Molded	24----	105884	Comfo Bite Mouthpiece, Clear, Standard
8b----	103732	Demand Diaphragm (U.S. Military Only)	-----	105885	Comfo Bite Mouthpiece, Black, Standard
9----	101919	Exhaust Tee	-----	105889	Standard Mouthpiece, Clear
10----	105139	Exhaust Valve	-----	105879	Standard Mouthpiece, Black
11----	100444	Inlet Fitting	25----	820010	O-ring
12----	820014	O-ring	26----	090015	Hose Assy, 3/8" x 30"
13----	108510	LP Seat	-----	APF124565	Hose Assy, 1/2" x 30", w/Protector
14----	104903	Poppet	27----	957025	O-ring (Conshelf 30)
15----	108504	Spring (Standard)	-----	820011	O-ring (Standard)
-----	108514	Spring (Octopus)			
16----	108122	Box Bottom			
-----	108535	Box Bottom Kit (includes 16, 17 & 18)			
17----	957025	O-ring			

Part numbers in **BOLD ITALICS** indicate standard overhaul replacement part.

First-Stage Exploded Parts Drawing

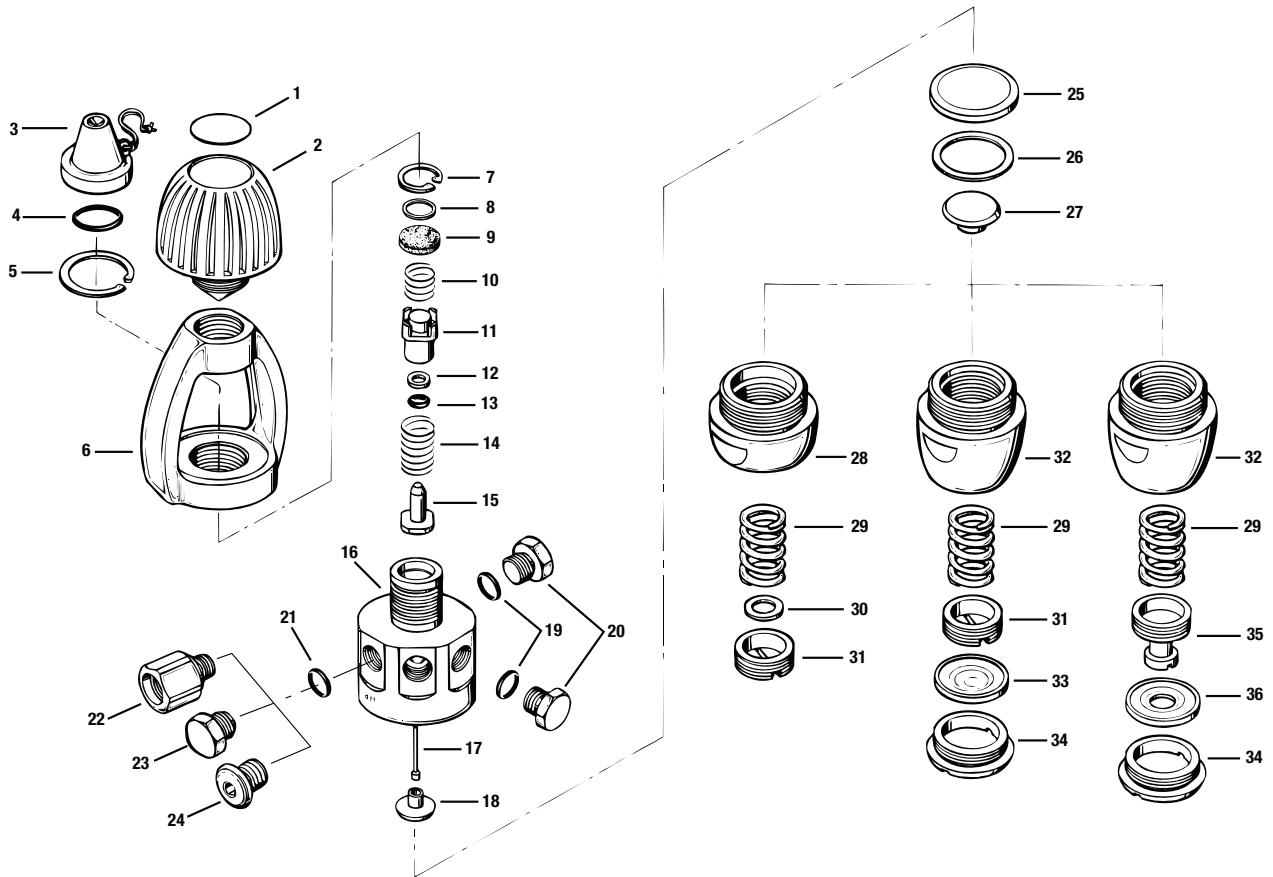

Key #	Part #	Description
----	107700	First-Stage, Conshelf XIV
----	108810	First-Stage, Conshelf XIV Supreme
----	900001	Overhaul Parts Kit, non-Supreme
----	108195	Overhaul Kit, Milit. Conshlf XIV (1st & 2nd)
1----	100388	Decal
2----	107506	Yoke Screw
3----	101012	Dust Cap
4----	820120	O-Ring
5----	861068	Retaining Ring
6----	700418	Yoke
7----	863051	Retaining Ring
8----	845095	Washer, Filter
9----	105106	Filter
10----	104613	Spring
11----	105324	Spring Block
12----	828005	Back-up Ring
13----	820080	O-ring
14----	101504	Spring
15----	105940	Seat
16----	105333	Body, Conshelf XIV
----	100712	Body, Conshelf 21&22 (w/removable crown)
17----	105323	Pin
18----	101727	Pin Support
19----	820011	O-ring, 3/8" port
20----	910912	Port Plug, LP, Conshelf XIV
----	104304	Port Plug, LP, Conshelf 20, 21, 22
21----	957004	O-ring, 7/16" HP Port
----	820011	O-ring, 3/8" HP Port (Con XIV, pre-1998)
22----	101785	Adapter, HP, 7/16" Fem. to 3/8" Male
23----	910912	Port Plug, HP, 3/8" (Con. XIV, pre-1998)
24----	102003	Port Plug, HP, 7/16"

Key #	Part #	Description
25----	103429	Diaphragm
26----	821026	Thrust Washer
27----	101728	Spring Pad
28----	105926	Spring Retainer (fine thread)
----	105326	Spring Retainer (coarse thread)
29----	105327	Spring
30----	845097	Washer, Main Spring (non-supremes only)
31----	106023	Adjustment Screw (fine thread)
----	101549	Adjustment Screw (coarse thread)

USED ON SUPREME MODELS

29----	105944	Spring (coarse thread Supreme only)
----	105327	Spring (fine thread & EFA Supreme)
32----	105927	Spring Retainer (fine thread)
----	108851	Spring Retainer (coarse thread)
33----	108853	Secondary Diaphragm
34----	108854	Diaphragm Retainer
n/s----	108865	Silicone Fluid
----	108855	Silicone Fluid (Military Only)

USED ONLY ON EXTERNALLY FINE ADJUSTABLE SUPREME

36----	105936	Adjustment Screw, EFA Supreme
37----	108852	Secondary Diaphragm, EFA Supreme
n/s----	108865	Silicone Fluid

Part numbers in **BOLD ITALICS** indicate standard overhaul replacement part.



2340 Cousteau Court, Vista, California 92083

www.aqualung.com